

VARIANT 19-³/₄" x 14"
OVAL ABOVE
COUNTER BASIN

Cat.No.
 5-502WH



W: 19-3/4"
 D: 14"
 H: 5"

Features:

- ▶ Above counter basin
- ▶ Vitreous china for durability
- ▶ No overflow
- ▶ Drain not provided
- ▶ Can be used with grid drain #5601 or umbrella drain # UD701 (Not included)

Colors:
 WH White

Compliance Certification
 Meets or exceeds the following specifications: ASME A112.19.2 2018 and CSA B45.1-18 for ceramic plumbing fixtures.

***Please do NOT drill hole without actual product.**

Interior Dimensions:

Basin Interior: 18-³/₄" x 13-³/₄"
 Basin Depth: 3-¹/₂"
 Back of basin to center of drain: 7"

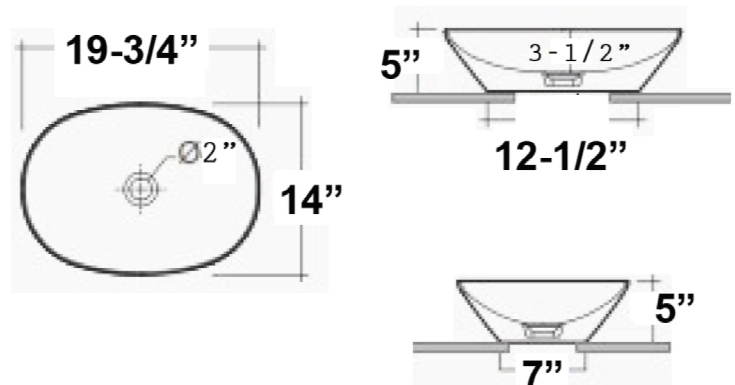

Dimensions of fixture are nominal and may vary within the range of tolerances established by AMSE Standard A112.19.2.2013 Dimensions and specifications subject to change without notice.